

LINDNER



**KOMET 1800 | 2200 | 2800
STATIONARY SECONDARY SHREDDING**

**UNBELIEVABLY
PRECISE.**

ONLY LINDNER CLIENTS CAN TRULY SAY:

THAT'S HOW DEFINED PARTICLE SIZE WORKS.

PRECISION THAT'S A CUT ABOVE THE REST.

The Lindner Komet sets new standards in single-shaft shredding. Whether you are processing municipal or bulky refuse, industrial or commercial waste, textiles, waste paper or other materials – the Komet ensures smooth processes 24/7 thanks to its robust design, high-precision tools and smart features. Benefit from its first-rate particle quality and superb efficiency.



1. HYDRAULIC MAINTENANCE DOOR

Remove non-shreddables quickly and cleanly with the maintenance door at position 2.

100% safe operation with the mechanical safety lock and the pusher's special parking position.

Enjoy comfortable maintenance access to the cutting chamber with the maintenance door at position 3.



2. SINGLE-STEP BELT DRIVE

Efficient, stable and gearless belt drive.

Low maintenance with simple, tried-and-tested design.

Readily available and easily exchangeable standard parts.



3. TORQUE-LIMITING SAFETY CLUTCH

Perfect drive protection thanks to the drive unit's lightning-speed disengagement.

Fully adjustable to your materials.

Secure power down with our proven sensors.

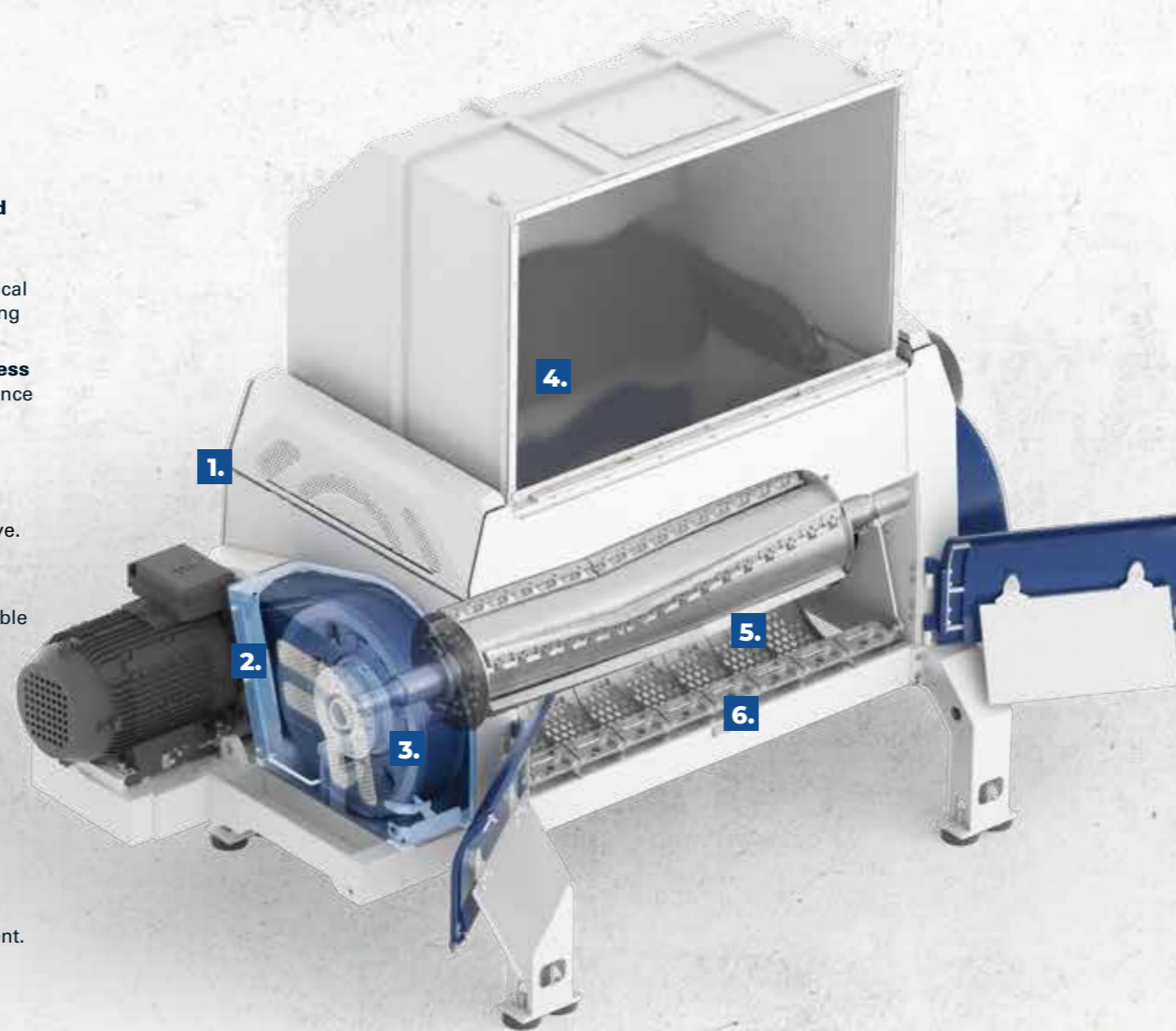

4. INTERNAL PUSHER

Continuous shredding due to smooth feeding.

Easy feeding with a completely internal construction.

Maintenance-free thanks to the absence of guide elements.



5. HIGH-PRECISION SHEAR CUTTING SYSTEM

High output guaranteed with signature cutter geometry.

Consistent particle size – cutting gap fully adjustable even during operation.

Parts storage made easy thanks to identical cutters, counter knives and scrapers.

Maximum service life ensured by four-fold usable, quick-change cutters.



6. PLUG & GO SCREEN UNIT

Flexible output sizes made possible with quick-change screen units in different hole sizes.

Easy access for maintenance and fitting thanks to the swivel-mounted, hydraulically operated design.

Extremely safe operation with the electromagnetically locked screen access point, preventing access to the cutting chamber while the machine is in operation.



TECHNICAL DATA

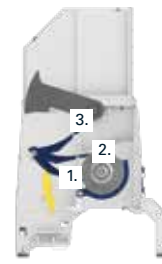
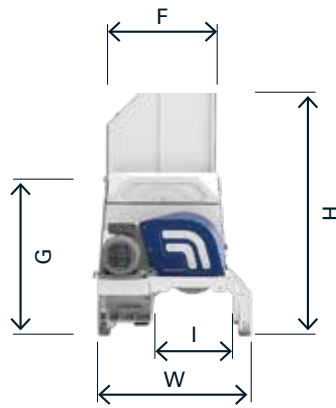
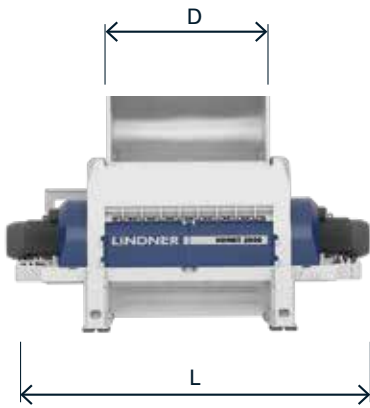

Hydraulic door for maintenance and removal of foreign objects

1. Operating position
2. Position for removal of foreign objects
3. Position for maintenance

| | | KOMET 1800 | KOMET 2200 | KOMET 2800 |
|----------------------|-------------------|----------------------|----------------------|----------------------|
| DIMENSIONS* | | | | |
| Measure (LxWxH) | mm | 4924 x 2925 x 3111 | 5755 x 2925 x 3111 | 6445 x 2925 x 3111 |
| Hopper opening (DxF) | mm | 1790 x 2030 | 2135 x 2030 | 2825 x 2030 |
| Capacity | m ³ | 3.3 | 4 | 5.3 |
| Outlet width (I) | mm | 960 | 960 | 960 |
| Weight | kg | 18500 | 22500 | 26000 |
| CUTTING UNIT* | | | | |
| Length | mm | 1770 | 2115 | 2805 |
| Speed | min ⁻¹ | 355 | 355 | 355 |
| Standard tool | | blade knives 172R | blade knives 172R | blade knives 172R |
| Number of knives | pcs. | 50 | 60 | 80 |
| Screens | | hexagonal/round | hexagonal/round | hexagonal/round |
| Number of screens | pcs. | 5 | 6 | 8 |
| Final output | mm | 10–100 | 10–100 | 10–100 |
| DRIVE UNIT* | | | | |
| Type | | 1-step belt drive | 1-step belt drive | 1-step belt drive |
| Motor | kW | 1 x 200 | 2 x 132 | 2 x 160 |
| Power control | | frequency converter | frequency converter | frequency converter |

*The stated values refer to standard machine versions with a standard hopper and raised feet. The right to make technical changes is reserved.



Atex-explosion protection



Bus connection to the external control system



Fire extinguishing system with spark detection



Cutting system cooling

Lindner-Recyclingtech GmbH

Villacher Strasse 48 | 9800 Spittal/Drau | Austria
t.: +43 4762 2742 | f.: +43 4762 2742-9032 | office@lindner.com

www.lindner.com